

# LC/2 TR-S

Tavola Rotante / Rotary Table

**LAMPUGNANI  
SABBIATRICI**  
*experience since 1976*



## DATI TECNICI / Technical Data

<b>dim. utili/useful dim. mm.</b>	1100 x 850 x 750 H.
<b>dim. ingombro/overall</b>	1170 x 950 x 1950 H.
<b>portelle/doors</b>	nr. 2
<b>tavola rotante/rotary table</b>	Ø 700
<b>elettrovent. /electric fan</b>	HP. 0,25
<b>peso/weight</b>	Kg. 200
<b>portata/load</b>	Kg. 200
<b>consumo aria/air consump.</b>	110>780 lt/1' (1>7 BAR)
<b>alim. elettrica/electric</b>	400/240 V 50 Hz

## CARATTERISTICHE

La Sabbiatrice / Pallinatrice Mod. LC/2 TR-S è indicata per piccole, medie e grandi produzioni con possibilità di facili e veloci "cambi sabbia". La tavola rotante, montata di serie su cuscinetti a tenuta stagna, permette la rotazione manuale di pezzi con forme complesse, facilitando le operazioni di sabbiatura/pallinatura.

È possibile aggiungere il CICLONE separatore anche in un secondo tempo.

Consigliamo l'utilizzo del filtro a cartuccia certificato in armadio metallico Mod. **SE/1** o **LAC/10**.



## Features

The sandblasting/shot-peening machine Mod. LC/2 TR-S is indicated for small, medium and large productions with possibilities of quick and easy "media changes". The rotating table, installed on a set of airtight bearings, can be used for manual rotation of pieces with complex shapes, permits easier sandblasting / shot-peening operations.

It is possible to add the CYCLONE also in a second time.

We recommend to use Lampugnani certified cartridge filter cabinet Model **SE/1** or **LAC/10**.



*Finiture di Qualità.*



**Funzionamento Ciclone e Filtro**  
Cyclone and Filter operation

**Mod. CL/40**  
Ciclone/Cyclone\*

**Mod. SE/1**  
Filtro/Filter\*\*

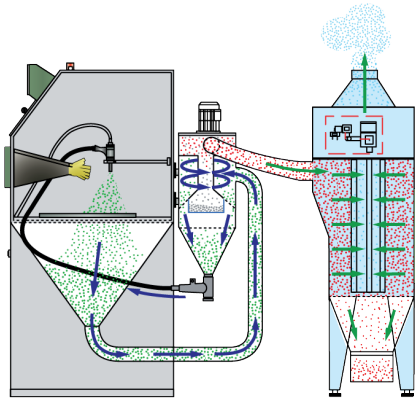

Il **Ciclone** tramite forza centrifuga seleziona e separa le polveri che si creano durante il ciclo di sabbiatura e pallinatura. Il **Filtro** a cartuccia certificato Mod. SE/1 trattiene le polveri di lavorazione e garantisce un ottimo equilibrio dell'impianto.

*Through the centrifugal force, the cyclone selects and separates the dust that is created during the sandblasting and shot-peening cycle. The certified cartridge filter Mod. SE/1 retains the processing dust and ensures an excellent balance of the sandblasting system.*

dimensioni/dimensions  
**mm. 600 x 500 x 1200 H.**

elettroventilatore/electric-fan  
**HP. 0.75**

peso/weight  
**Kg. 30**

setaccio vagliatore  
screen sieve

(\*optional)

dimensioni/dimensions  
**mm. 620 x 640 x 1890 H.**

superficie filtrante /filt. surface  
**m<sup>2</sup> 3**

peso/weight  
**kg. 70**

pulizia cartuccia automatica  
automatic cartridge cleaning

(\*\*optional)

**Dimensioni e Ingombri mm. / Useful and Overall Dimensions mm.**

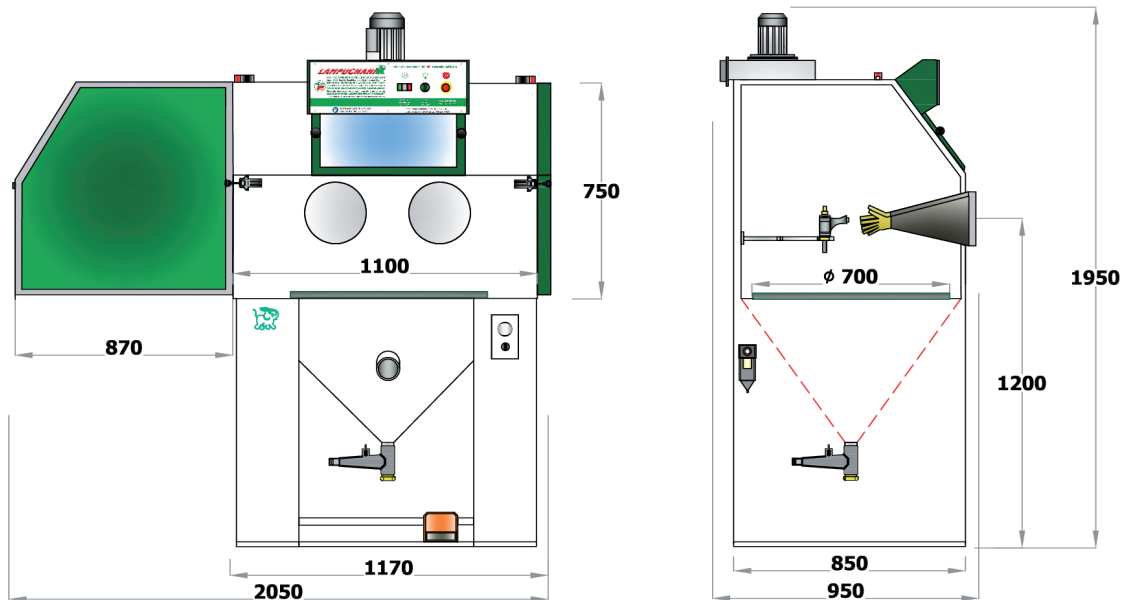

Con riserva di variazione delle specifiche tecniche senza preavviso.  
With right to change technical specifications without notice.  
LAMPUGNANI 01-20-R01

**Microsfere e Abrasivi / Microbeads and Abrasives**

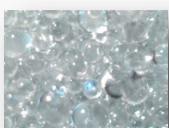

**MICROSFERE VETRO**  
glass microbeads



**MICROSFERE CERAMICA**  
ceramic microbeads

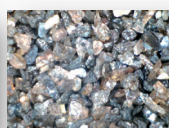

**CORINDONE BRUNO**  
red-brown corundum



**CORINDONE BIANCO**  
white corundum

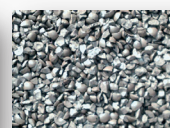

**GRANIGLIA ANGOLARE**  
cast iron

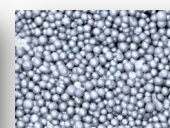

**GRANIGLIA SFERICA**  
steel beads



**GRANULI PLASTICI**  
plastic granules

**LAMPUGNANI SABBIATRICI Srl**

Via De Vecchi, 21 - 20057 Assago (Milano) Tel +39 02 48 84 03 50 Fax +39 02 48 84 03 64

www.sabbiatrici.com



sabbia@lampugnani.it

